

AIR SHOWER

Design according to requirements of body size, operation method, various options, etc.



Air shower for workers

Specifications case

Standard type air shower for workers (AS-1000AA)

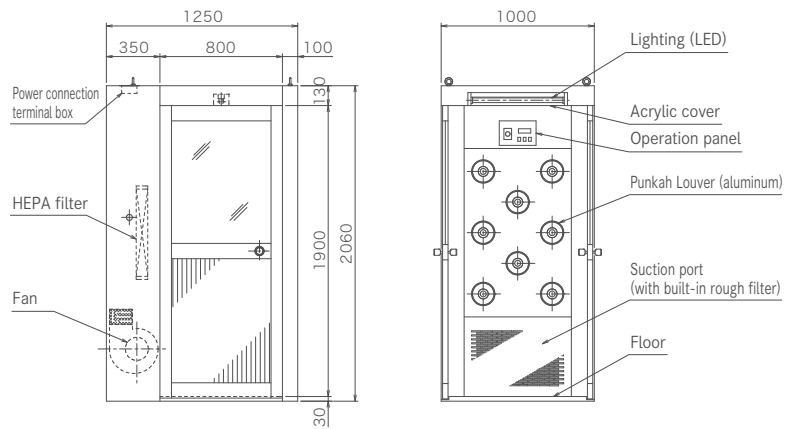

Standard Specifications / Type

Model	AS-1000AA	AS-1000BB	AS-1500AA	AS-2000BB
Dust collection efficiency	99.97% or more for 0.3μm PAO particles			
Dust collecting filter	Prefilter: Washable nonwoven fabric Main filter: HEPA filter			
Blowout air velocity (50Hz/60Hz)	Approximately 23/25 m/s			
L dimension of the body	1000mm		1500mm	2000mm
Blowout nozzle	8 pieces	16 pieces	8 pieces	32 pieces
Body	Bonderized steel plate with melamine baking finishing			
Effective dimension of the clearance	800mm			
Start-up method	Timer interlock	Photoelectric switch		
	Continuous	Manual changeover switch		
Lighting	20W		40W	
Power consumption (W)	470/640	940/1180	470/640	1880/2360

Category	Type	
Blowout	Single blowing	
	Double blowing	
	Combination with ceiling blowing	
Door	Manual	Slide type Swing type Single-opening Double-opening
	Automatic	
	Air Curtain	
	Go straight	
Direction of entry and exit	L-type (rectangular)	
	T-type (three-way door)	
Floor	Yes	Flat type Grating type
	Non	Use the existing floor
Start of air blowing	Photoelectric switch	
	Pushbutton switch	
Explosion proof	Non-explosion-proof (standard)	
	Improved explosion resistance	
	Explosion-proof	

Explanation of Model

AS - 1000 A A	① Air shower	③ A: Single blowing B: Double blowing
① ② ③ ④	② L dimension (mm)	④ A: Manual door B: Automatic door

- Other models are also available.
We will design the size and operation method upon request.
- Options are as follows.
Air curtain / Electromagnetic lock / Interphone / Ceiling blowing